

Installation Guides for ControlMate 2 and ControlMate FM

Contents

ControlMate FM

Installation Guide
Equipment requirements (Figure 1)
Installation Plan (Figure 2 and Figure 2a)
Basic Set-up

ControlMate 2P

Installation Guide
Equipment requirements (Figure 3)
Installation Plan (Figure 4 and Figure 4a)
Basic Set-up

Cla-Val PRV diagram (Figure 5)
Cla-Val PRV Locking in the set position (Figure 6)
Cla-Val PRV Locking in the set position (Figure 7)

Bermad PRV diagram (Figure 8)
Bermad PRV Locking in the set position (Figure 9)

In-Bal PRV diagram (Figure 10)



CM IG Issue 4 January 2003

Palmer Environmental
Ty Coch House
Llantarnam Park Way
Cwmbran
NP44 3AW
United Kingdom

Tel: +44 (0) 1633 489479
Fax: +44 (0) 1633 877857
Email: info@palmer.co.uk
Web: www.palmer.co.uk

Installation Guide For Palmer ControlMate-FM

The following step numbers refer to the arrow numbers on the “ControlMate-FM Installation Plan”

- 1) Connect flow pulse unit from meter to ControlMate box (only if using flow to control desired pressure)
- 2) Cut a length of blue pipe long enough to connect PRV downstream pressure to solenoid box.
- 3) Connect a female quick fit connector to one end of blue pipe and insert into solenoid box male connector.
- 4) Connect a male quick fit connector to other end of blue pipe and insert into the downstream pressure female connector on the PRV.
- 5) Cut a short length of red pipe (approx. 150mm) and connect one end to red port on solenoid box.
- 6) Connect filter to other end of red pipe (black end)
- 7) Cut a short length of red pipe (approx. 150mm) and connect one end to filter (red end)
- 8) Connect other end of red pipe to one of the double outlets from the pipe splitter.
- 9) Cut a short length of red pipe (approx. 300mm) and connect one end to the remaining double outlet from the pipe splitter.
- 10) Connect a female quick fit connector to the other end of the red pipe and insert into the remaining solenoid box male connector.
- 11) Cut a short length of red pipe (approx. 750mm) and connect one end to the single outlet from the pipe splitter.
- 12) Connect other end of the red pipe to pipe tee.
- 13) Cut a short length of red pipe (approx. 750mm) and connect one end to pipe tee.
- 14) Connect other end of the red pipe to the red port on the 3-way valve tee. Make sure the 3-way valve tee handle is pointing towards the green port.

- 15) Cut a length of red pipe long enough to connect the PRV to the pipe tee. Connect one end to the remaining port on the pipe tee.
- 16) Connect a male quick fit connector to the other end of the red pipe and insert into the upstream pressure female connector on the PRV.
- 17) Lock PRV in set position and remove adjusting screw from PRV pilot. Replace this with the Palmer Actuator, screwing in approximately the same distance as the removed screw.
- 18) Cut a length of green pipe long enough to connect the Palmer Actuator to the 3-way valve tee. Connect one end of the green pipe to the black port on the 3-way valve tee and the other end to the top of the Palmer Actuator.
- 19) Cut a length of green pipe long enough to connect the 3-way valve tee to the solenoid box. Connect one end to the remaining green port on the 3-way valve tee and the other end to the remaining green port on the solenoid box.

The PRV can now be un-locked slowly, whilst watching the downstream pressure on the ControlMate. Alter the Palmer Actuator by screwing in or out to return the downstream pressure to the approximate setting before installation began.

Set Up Notes For Palmer Actuator

Screw in the Palmer Actuator slowly clockwise till the desired maximum downstream pressure +2m is displayed on the ControlMate. Leave a few minutes to make sure the pressure settles. Lock the bottom nut in place.

Hold the center bolt in place whilst screwing out the Palmer Actuator slowly anti-clockwise till the desired minimum downstream pressure -2m is displayed on the ControlMate. Leave for a few minutes to make sure the pressure settles. Lock the top nut in place.

Now follow ControlMate-FM Basic Setup Notes.

Equipment Requirements For ControlMate-FM Installation

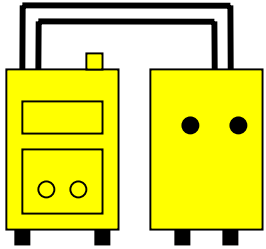

1 x ControlMate-FM & attached solenoid box



1 x Filter



1 x Palmer Actuator



1 x Pipe Splitter



1 x Pipe Tee

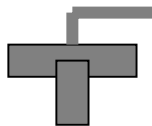

1 x 3 Way Valve Tee

Note :

It is advisable to have some means of fixing the ControlMate and solenoid box to the wall of the chamber.



Red Pipe



Blue Pipe



Green Pipe



2 x Male quick fit connectors
2 x Female quick fit connectors



1 x Flow Pulse Unit

Figure 1

ControlMate-FM Installation Plan

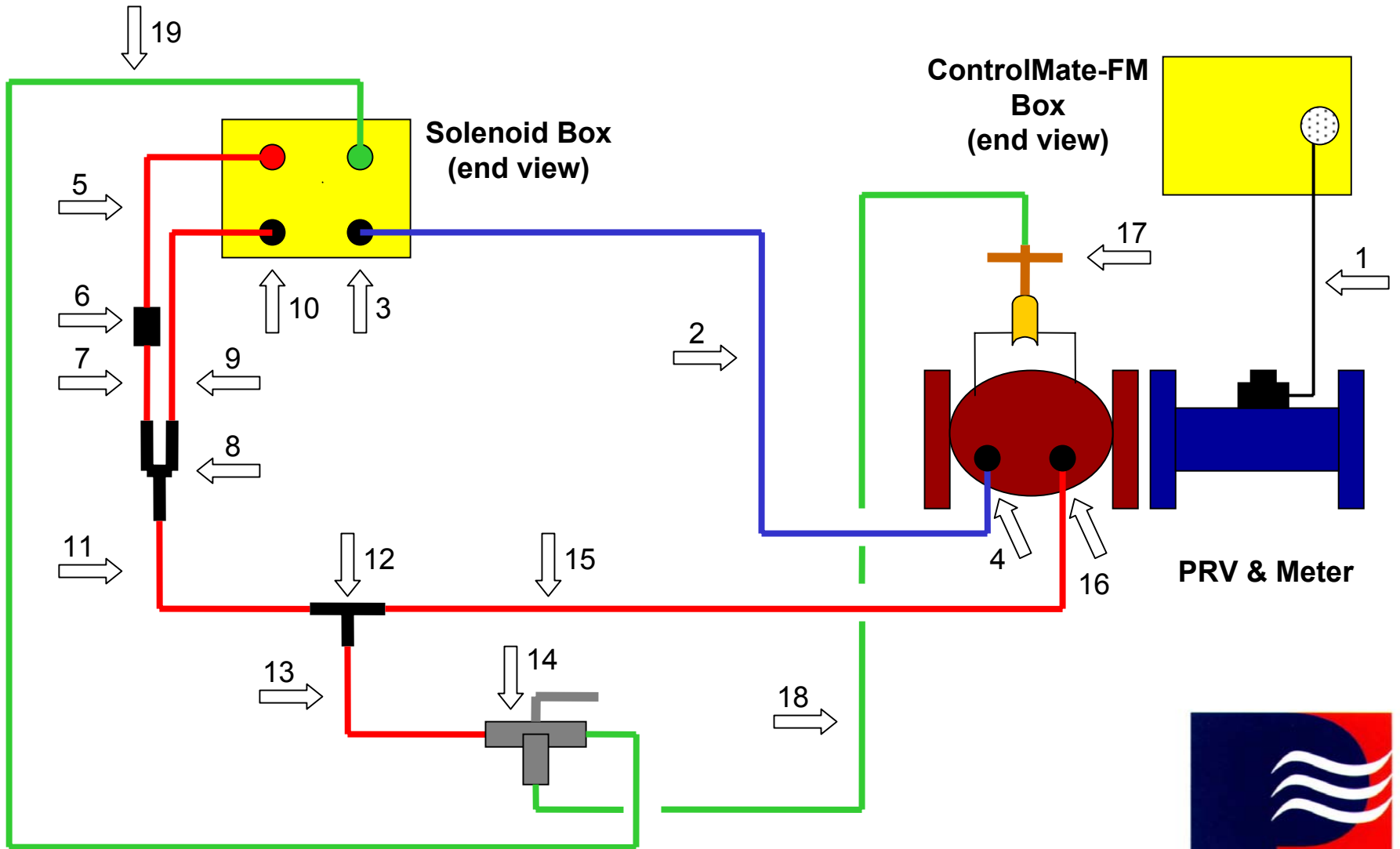

Figure 2

ControlMate-FM Installation Plan (For inlet pressures of 90m and above)

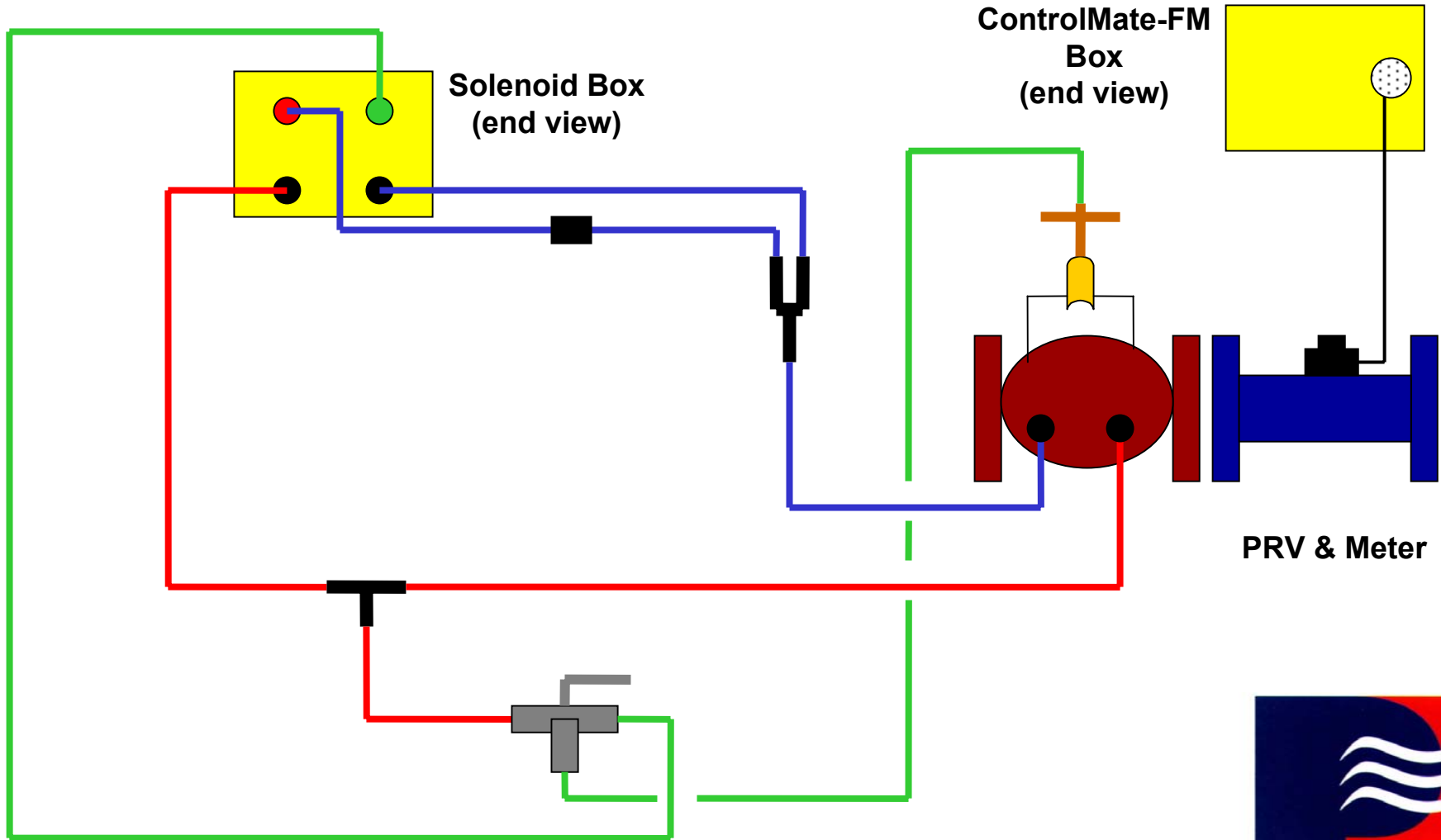

Figure 2a

ControlMate-FM Basic Setup Notes

Note

On the notes below a step stating “Choose” means using the “**Select**” button to toggle to the desired selection and the “**Next**” button to execute the selection.

On ControlMate - FM

Install ControlMate-FM on PRV as per installation plan and guidance notes, once Palmer Actuator is set correctly follow the instructions below to setup the ControlMate-FM.

- 1) Turn controller on by holding down “**Next**” button
- 2) Press “**Next**” button to Setup screen
- 3) Choose “**Setup**” on the Continue screen
- 4) Press “**Next**” button 3 times to get through the default Pin Code of 000
- 5) Press “**Next**” button to get through Date & Time screen
- 6) Press “**Next**” button to get through the Battery screen
- 7) Choose “**Auto Time**” or “**Auto Flow**” on Current Settings screen
- 8) Choose “**OK**” on Confirm screen
- 9) Enter Litres / Pulse value (“**Select**” button changes value, “**Next**” button moves to next value, only if connecting to flow). Choose “**OK**” on the Confirm screen
- 10) Press “**Next**” button to progress through User Pin screen
- 11) Choose “**Values**” to progress through the Continue screen
- 12) Press “**Select**” to show options Edit, Insert, Delete, End
- 13) Choose “**Edit**” to progress through to Flow (or Time) & Pressure values 1
- 14) Enter Flow (or Time) value 1 (“**Select**” button changes value, “**Next**” button moves to next value)
- 15) Enter Pressure value 1 (“**Select**” button changes value, “**Next**” button moves to next value)

- 16) Choose **“OK”** on the Confirm screen
 - 17) Press **“Next”** button to progress through to Flow (or Time) & Pressures values 2
 - 18) Press **“Select”** to show options Edit, Insert, Delete, End
 - 19) Choose **“Edit”** to progress through to Flow (or Time) & Pressure values 2
 - 20) Enter Flow (or Time) value 2 (**“Select”** button changes value, **“Next”** button moves to next value)
 - 21) Enter Pressure value 2 (**“Select”** button changes value, **“Next”** button moves to next value)
 - 22) Choose **“OK”** on the Confirm screen
 - 23) Press **“Next”** button to progress through to Add New Values screen
 - 24) Choose **“Add”** to progress through the Add New Values screen
 - 25) Enter Flow (or Time) value 3 (**“Select”** button changes value, **“Next”** button moves to next value)
 - 26) Enter Pressure value 3 (**“Select”** button changes value, **“Next”** button moves to next value)
 - 27) Choose **“OK”** on the Confirm screen
 - 28) Press **“Next”** button to progress through to Add New Values screen
 - 29) Choose **“Add”** to progress through the Add New Values screen
 - 30) Enter Flow (or Time) value 4 (**“Select”** button changes value, **“Next”** button moves to next value)
 - 31) Enter Pressure value 4 (**“Select”** button changes value, **“Next”** button moves to next value)
 - 32) Choose **“OK”** on the Confirm screen
 - 33) Press **“Next”** button to progress through to Add New Values screen
- Repeat steps 29–33 to enter more values, otherwise follow step 34**
- 34) Choose **“End”** instead of Add to conclude set up of Controller.

Installation Guide For Palmer ControlMate-2P

The following step numbers refer to the arrow numbers on the “ControlMate-2P Installation Plan”

- 1) Connect flow pulse unit from meter to ControlMate box (only if using flow to control desired pressure)
- 2) Cut a length of blue pipe long enough to connect PRV downstream pressure to the ControlMate box.
- 3) Connect a female quick fit connector to one end of blue pipe and insert into ControlMate box male connector.
- 4) Connect a male quick fit connector to other end of blue pipe and insert into the downstream pressure female connector on the PRV.
- 5) Cut a short length of red pipe (approx. 150mm) and connect one end to red port on ControlMate box.
- 6) Connect filter (black end) to other end of red pipe.
- 7) Cut a short length of red pipe (approx. 150mm) and connect one end to filter (red end)
- 8) Connect other end of red pipe to one of the double outlets from the pipe splitter.
- 9) Cut a short length of red pipe (approx. 300mm) and connect one end to the remaining double outlet from the pipe splitter.
- 10) Connect a female quick fit connector to the other end of the red pipe and insert into the remaining ControlMate box male connector.
- 11) Cut a short length of red pipe (approx. 750mm) and connect one end to the single outlet from the pipe splitter.
- 12) Connect other end of the red pipe to pipe tee.
- 13) Cut a short length of red pipe (approx. 750mm) and connect one end to pipe tee.
- 14) Connect other end of the red pipe to the red port on the 3-way valve tee. Make sure the 3-way valve tee handle is pointing towards the green port.

- 15) Cut a length of red pipe long enough to connect the PRV to the pipe tee. Connect one end to the remaining port on the pipe tee.
- 16) Connect a male quick fit connector to the other end of the red pipe and insert into the upstream pressure female connector on the PRV.
- 17) Lock PRV in set position and remove adjusting screw from PRV pilot. Replace this with the Palmer Actuator, screwing in approximately the same distance as the removed screw.
- 18) Cut a length of green pipe long enough to connect the Palmer Actuator to the 3-way valve tee. Connect one end of the green pipe to the black port on the 3-way valve tee and the other end to the top of the Palmer Actuator.
- 19) Cut a length of green pipe long enough to connect the 3-way valve tee to the ControlMate box. Connect one end to the remaining green port on the 3-way valve tee and the other end to the remaining green port on the ControlMate box.

The PRV can now be un-locked slowly, whilst watching the downstream pressure on the ControlMate. Alter the Palmer Actuator by screwing in or out to return the downstream pressure to the approximate setting before installation began.

Set Up Notes For Palmer Actuator

Screw in the Palmer Actuator slowly clockwise till the desired maximum downstream pressure is displayed on the ControlMate. Leave a few minutes to make sure the pressure settles. Lock the bottom nut in place.

Hold the center bolt in place whilst screwing out the Palmer Actuator slowly anti-clockwise till the desired minimum downstream pressure is displayed on the ControlMate. Leave for a few minutes to make sure the pressure settles. Lock the top nut in place.

Now follow ControlMate-2P Basic Setup Notes.

Equipment Requirements For ControlMate-2P Installation

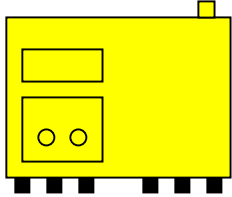

1 x ControlMate-2P



1 x Filter



1 x Palmer Actuator



1 x Pipe Splitter



1 x Pipe Tee

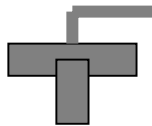

1 x 3 Way Valve Tee

Note :

It is advisable to have some means of fixing the ControlMate to the wall of the chamber.



Red Pipe



Blue Pipe



Green Pipe



2 x Male quick fit connectors
2 x Female quick fit connectors



1 x Flow Pulse Unit

Figure 3

ControlMate-2P Installation Plan

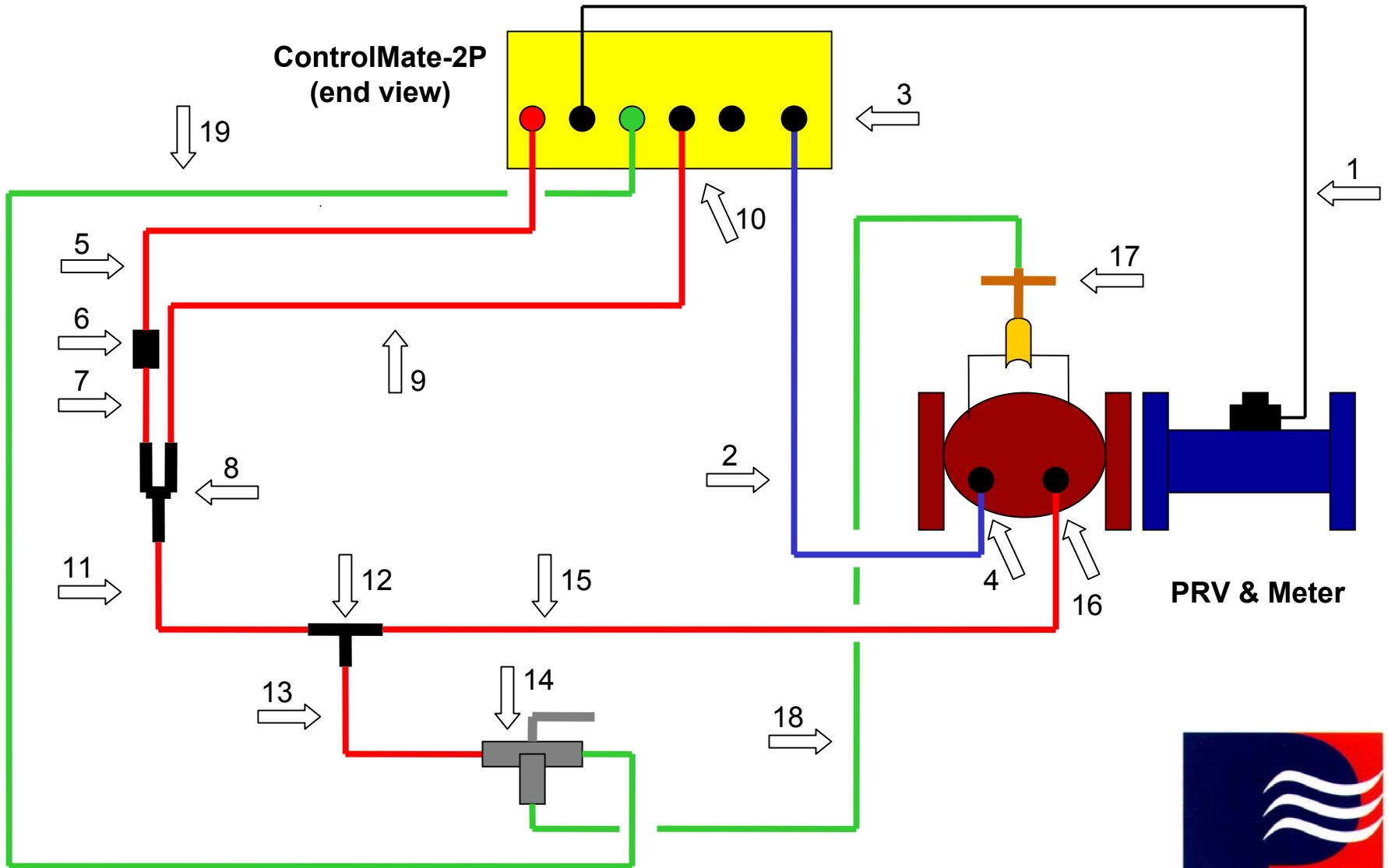
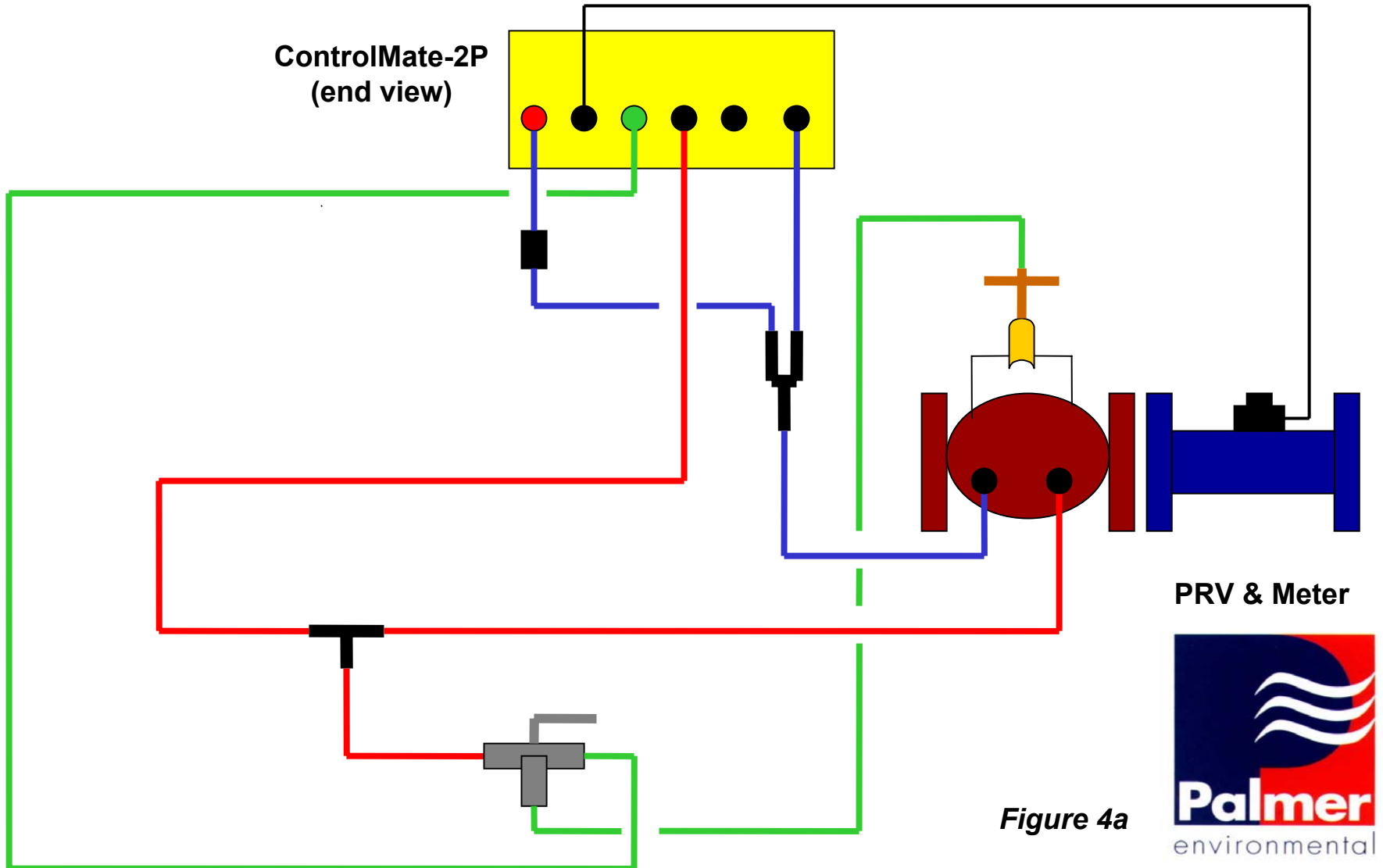

Figure 4

ControlMate-2P Installation Plan (For inlet pressures of 90m and above)



ControlMate-2P Basic Setup Notes

Note

On the notes below a step stating “Choose” means using the “**Select**” button to toggle to the desired selection and the “**Next**” button to execute the selection.

On ControlMate – 2P

Install ControlMate-2P on PRV as per installation plan and guidance notes, once Palmer Actuator is set correctly follow the instructions below to setup the ControlMate-2P.

- 1) Turn controller on by holding down “**Next**” button
- 2) Press “**Next**” button to Setup screen
- 3) Choose “**Setup**” on the Continue screen
- 4) Press “**Next**” button 3 times to get through the default Pin Code of 000
- 5) Press “**Next**” button to get through Date & Time screen
- 6) Press “**Next**” button to get through the Battery screen
- 7) Choose “**Auto Time**” or “**Auto Flow**” on Current Settings screen
- 8) Choose “**OK**” on Confirm screen
- 9) Enter Litres / Pulse value (“**Select**” button changes value, “**Next**” button moves to next value, only if connecting to flow)
- 10) Choose “**OK**” on the Confirm screen
- 11) Press “**Select**” on Minimum Pressure screen
- 12) Enter Pressure value (“**Select**” button changes value, “**Next**” button moves to next value) (Only enter a value here as a safety figure for fire demand purposes only)
- 14) Choose “**OK**” on Confirm Screen
- 13) Press “**Next**” button to progress through Minimum Pressure screen
- 14) Press “**Next**” to progress through User Code screen
- 15) Choose “**Values**” to progress through the Continue screen
- 16) Press “**Select**” to show options Edit, Insert, Delete, End
- 17) Choose “**Edit**” to progress through to Flow (or Time) & Low Pressure Value 1
- 18) Enter Flow (or Time) value 1 (“**Select**” button changes value, “**Next**” button moves to next value)
- 19) Enter Pressure value 1 (“**Select**” button changes to Low, “**Next**” button accepts choice)
- 20) Choose “**OK**” on the Confirm screen
- 21) Press “**Next**” button to progress through to Flow (or Time) & High Pressure value 2
- 22) Press “**Select**” to show options Edit, Insert, Delete, End
- 23) Choose “**Edit**” to progress through to Flow (or Time) & High Pressure Value 2
- 24) Enter Flow (or Time) value 2 (“**Select**” button changes value, “**Next**” button moves to next value)
- 25) Enter Pressure value 2 (“**Select**” button changes High, “**Next**” button accepts choice)
- 26) Choose “**OK**” on the Confirm screen
- 27) Press “**Next**” button to progress through to Add New Values screen
- 28) Choose “**Add**” to progress through the Add New Values screen
- 29) Choose “**End**” to conclude set up of Controller-2P

Cla-Val PRV Diagram

Flow Direction



Inlet pressure tapping

Outlet pressure tapping

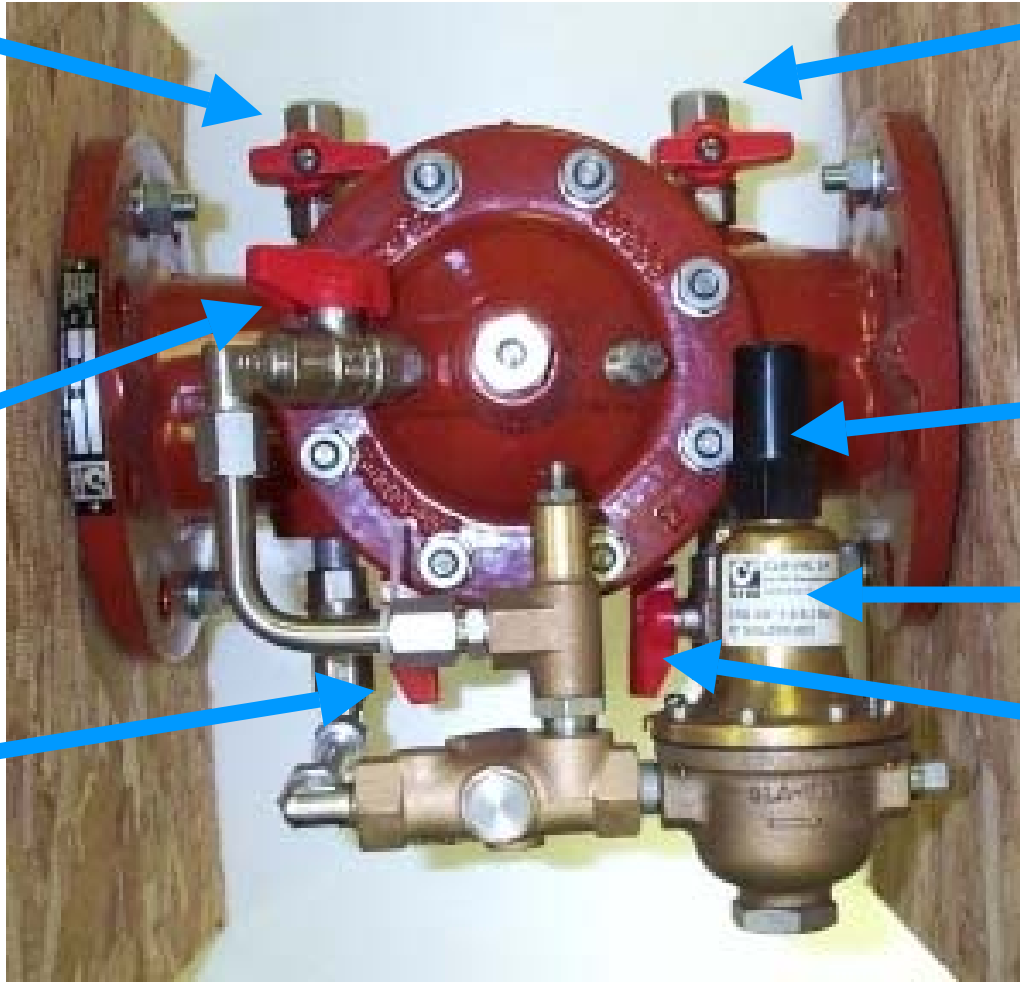

Top cover isolation valve

Pilot adjusting screw under black plastic cap

Inlet isolation valve

Pilot

Outlet isolation valve

Top View

Figure 5

Cla-Val PRV - Locking In The Set Position

Flow Direction



1) Close top cover isolation valve

Top View

Figure 6

Cla-Val PRV - Locking In The Set Position

Flow Direction



Note:- To un-lock PRV

1) Open inlet isolation valve

2) Open outlet isolation valve

3) Open top cover isolation valve

2) Close inlet isolation valve

3) Close outlet isolation valve

Side View

Figure 7

Bermad PRV Diagram

Flow Direction ↑



Top cover isolation valve

Pilot adjusting screw

Inlet pressure tapping

Pilot

Outlet isolation valve (hidden on side)

Inlet isolation valve (hidden on side)

Outlet pressure tapping

Top View

Figure 8



Bermad PRV - Locking In The Set Position

1) Close top cover isolation valve

3) Close outlet isolation valve

2) Close inlet isolation valve

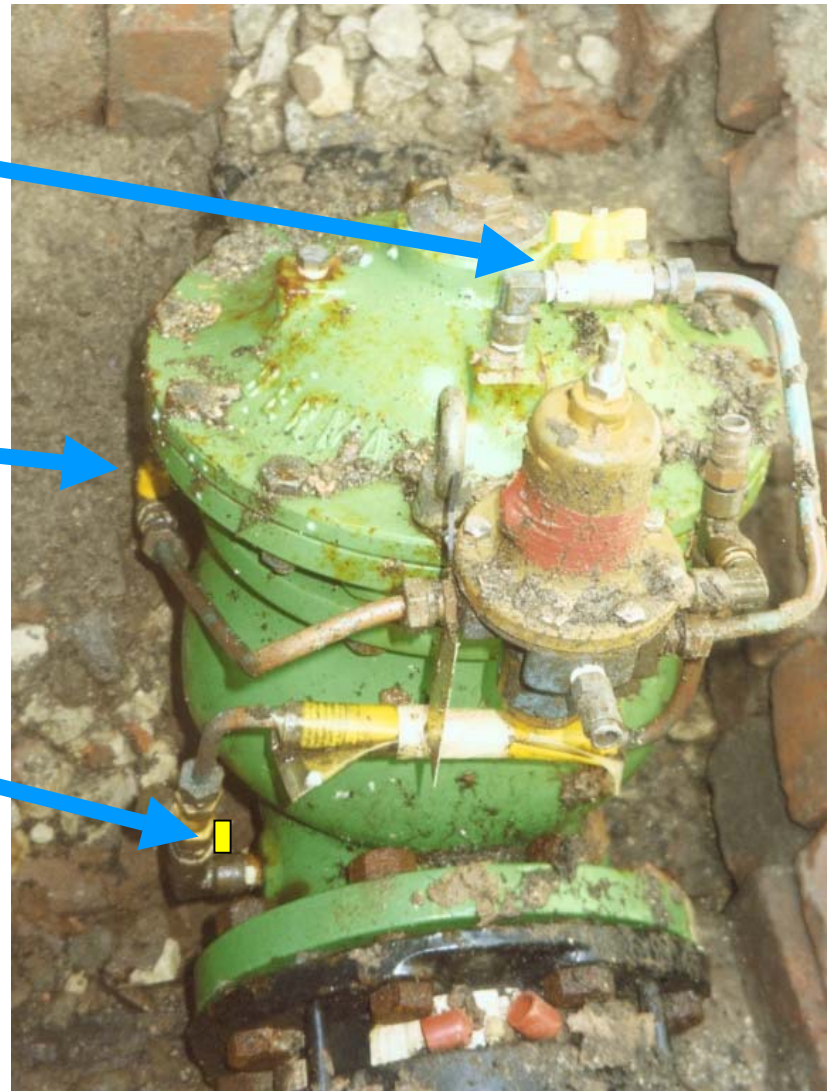

Side View

Note:- To un-lock PRV

1) Open inlet isolation valve

2) Open outlet isolation valve

3) Open top cover isolation valve

Flow Direction
↑

Figure 9

In-Bal PRV Diagram

Flow Direction



Inlet pressure tapping

Outlet pressure tapping

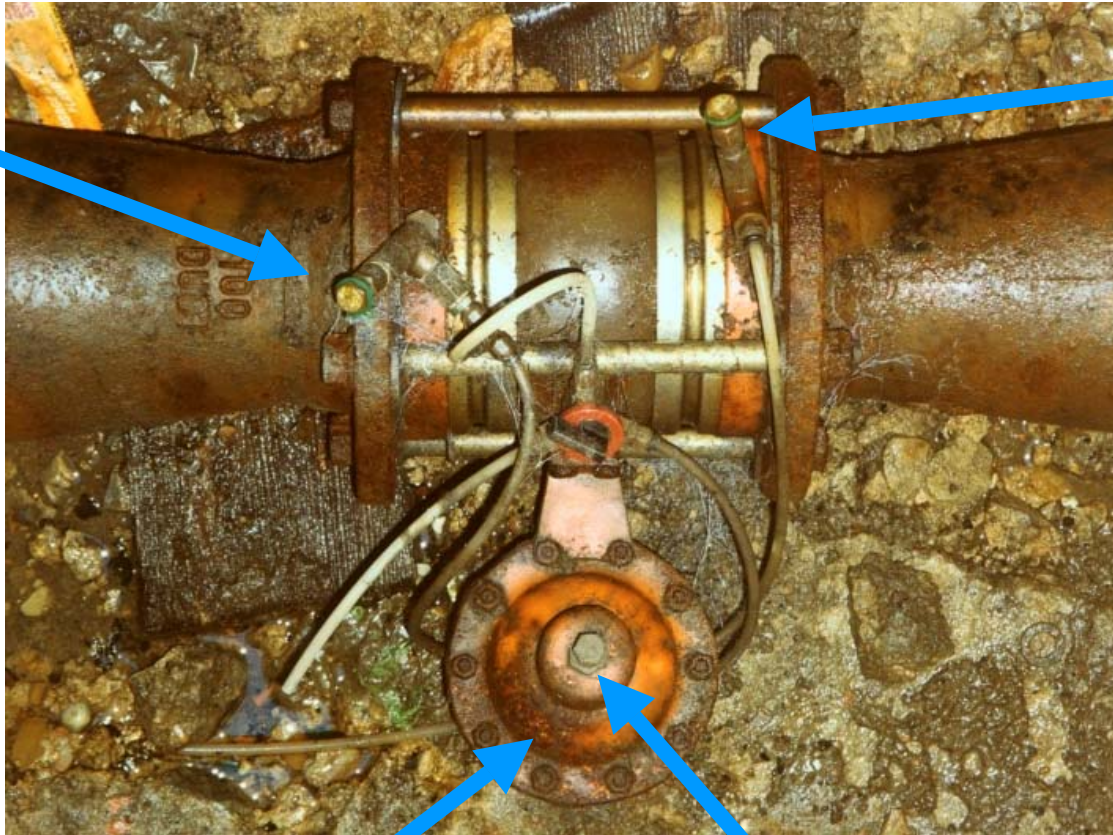

Pilot

Pilot adjusting screw

Top View

Figure 10